

FUNCTION CONTROL-----A NOVEL STRATEGY TO ACHIEVE IMPROVED PERFORMANCE OF THE DC-TO-DC SWITCHING REGULATORS

Yan-Fei Liu, Paresh C. Sen, Fellow IEEE
Power Electronics and Drives Lab
Dept. of Electrical Engg.
Queen's University
Kingston, Canada
K7L 3N6

Shi-Peng Huang
Dept. of Electrical Engg.
Zhejiang University
Hangzhou, 310027
P.R. China

Abstract --- The control strategy of the DC-to-DC switching converters is studied to obtain the switching regulators with zero-voltage regulation. A novel control strategy, the Function Control, is presented for the DC-to-DC switching converters to achieve this objective. The control law and the corresponding feedbacks are derived directly from the equations governing the switching converters. With the Function Control strategy presented in the paper, the switching regulators become robust, i.e., the output is independent of the disturbances from either the supply voltage or the load and exhibit other desirable advantages. The strategy is applicable to all the four basic PWM converters, i.e., Buck, Boost, Buck-Boost and Cuk. The analysis is confirmed by experiments and computer simulations.

I. INTRODUCTION

The four basic Switched-Mode PWM converters, Buck, Boost, Buck-Boost and Cuk are shown in Fig.1. These converters as well as other PWM converters [1,2] provide low voltage and current ratings for the switching devices and constant switching frequency control. With the emergence of the high speed devices, the switching frequency can be raised significantly in order to reduce the size of the power supply.

The control strategy for the switching regulators should be formulated to achieve the following desirable features:

- (a) the output voltage of the regulator remains unchanged even though there are disturbances from either the supply voltage or load current
- (b) the dynamic analysis of the switching regulator is valid for both small signal and large signal variations
- (c) the performance of the switching regulator can be predicted directly by the closed loop equations
- (d) the control circuit should be simple and flexible

Various attempts have been made to formulate the control strategies for the switching regulators because their overall dynamic performances are largely determined by the control strategy. The most commonly used one is the so-called direct-duty ratio control [1-4], as shown in Fig.2, where α is the duty ratio. It is a single loop control. The output voltage is sensed and compared with the reference voltage and the error is used to control the duty ratio. Unfortunately, it suffers from such

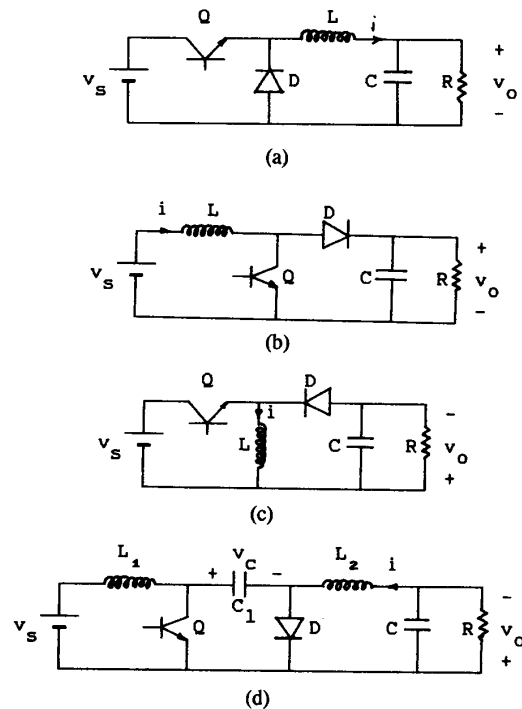

Fig.1 Basic switched-mode PWM converters, (a) Buck, (b) Boost, (c) Buck-Boost and (d) Cuk

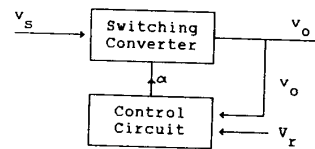

Fig.2 Block diagram for the direct duty-ratio control

drawbacks as large response time, difficulty to compensate, etc. Its implementation is simple. But it does not provide the zero-voltage regulation.

The current programming control [5-8], as shown in Fig.3, is superior to the direct-duty ratio control. The inductor current i and the output voltage v_o of the switching converter are both fed back. The output of the voltage controller acts as a current reference for the current comparator. Consequently, it has the advantages of wide bandwidth and automatic current limiting. However, because of its inherent instability and subharmonic oscillation [9] when operated at the constant switching frequency, extra compensating network is required.

The modern control theory has also been applied to control the switching regulators. The Sliding Mode Control (SLMC) [10-12] makes the closed-loop characteristics of a switching regulator determined solely by the control law. In Sliding Mode Control, the output voltage is independent of the parameters of power stage and the disturbances. Unfortunately, the switching frequency is not constant and the switching ripple is large.

In a large signal adaptive control strategy [13], the control law is derived by linearizing the large-signal state equation around a "varying" operating point instead of a fixed one. As a result, the control equations are constantly adjusted according to the environmental changes. Unfortunately, the control law is too complicated to be implemented in real time. It can not eliminate the effects of disturbances from either the supply voltage or the load current.

The authors in an earlier paper [14] attempted to synthesize the duty ratio α from the input and output quantities of the converter. With this control law, the switching regulator can eliminate the disturbance of the supply voltage. However, the load disturbance affects the output voltage and the analysis is in the small-signal domain.

The above review reveals that none of the foregoing control strategies achieve all the desirable characteristics of a switching regulator. In this paper, control strategies are studied in order to obtain the switching regulator with improved performance. A more general strategy of Function Control is presented for the DC-to-DC switching converters. The control law is constructed directly from the requirement of the power stage in order to provide zero-voltage regulation, making it independent of supply voltage and load disturbances. This new strategy is applied to the four basic switching converters, i.e., Buck, Boost, Buck-Boost and Cuk converters. Zero-voltage regulation is achieved in all the four topologies. This control strategy is simple to implement, is found to be able to eliminate the limitations of the previously proposed control strategies and is valid for both small-signal and large-signal variations. Both experimental results and computer simulations by PSPICE show that this strategy of Function Control possesses the desirable properties mentioned above.

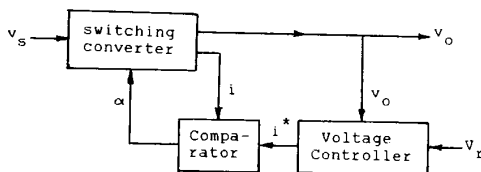

Fig.3 Block diagram for the current-programming control

II. BASIC PRINCIPLE OF THE FUNCTION CONTROL

A switching regulator has two essential parts: the switching converter and the control circuit. The output voltage of the switching converter depends on the supply voltage v_s , duty ratio α and a combination of intermediate variables of switching converter x , i.e.

$$v_o = f(v_s, x, \alpha) \quad (1)$$

The output of the control circuit is the duty ratio α and is dependent on the feedbacks, i.e.

$$\alpha = g(y, v_s, V_r) \quad (2)$$

where V_r is the reference voltage, y denotes a combination of the circuit variables in the switching converter. The components of y are feedback signals and are to be determined. All the variables in (1) and (2) except v_s , are averaged time-variant quantities. Mathematically, the duty ratio α produced by any control law can always be expressed in the form of (2), as shown in Fig.4. For example, in the case of direct duty ratio control with PI controller, only the output voltage is fed back, i.e., $y = 0$. The function g consists of integral and proportional operation. As for the current programming control, y is inductor current i of the switching converter and the relation $g(i, v_s, V_r)$ is a more complicated one.

Combining (1) and (2), the closed-loop output voltage v_o can be solved mathematically. It usually depends on the supply voltage and the load current, which implies that disturbances from the supply voltage and the load current have some effect, more or less, on the output voltage. This is not desirable for a constant voltage regulator. In order to achieve the zero-voltage regulation, the control strategy should be particularly constructed and the feedbacks should be properly selected so that the closed-loop output voltage is independent of either the supply voltage or the load current and is only determined by the reference voltage.

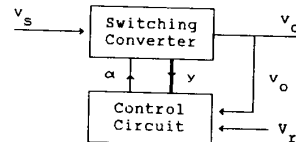

Fig.4 Generalized block diagram for the switching converter

Fortunately, the power stage has already provided with sufficient information as (a) how to construct the input and output relation of the control circuit and correspondingly, (b) how to select the feedbacks to achieve the desirable performance. This can be demonstrated more clearly if the duty ratio α in (1) is solved, assigned another symbol h , and expressed in terms of v_s , x and v_o , i.e.,

$$\alpha = h(v_s, x, v_o) \quad (3)$$

Equation (3) defines the duty ratio required by the switching converter at the operating point defined by v_s , x and v_o .

The control circuit can now be constructed to generate this duty ratio. The input and output relation of the control circuit is now constructed as:

$$\alpha_c = h[v_s, x, K(V_r - v_o)] \quad (4)$$

Equation (4) defines the control law, where α_c denotes the duty ratio generated by the control circuit, K is error amplifier coefficient. The term $(V_r - v_o)$ represents the negative feedback. The closed-loop characteristics of the switching regulator can be found from (3) and (4), as:

$$h(v_s, x, v_o) = h[v_s, x, K(V_r - v_o)] \quad (5)$$

From which the output voltage is:

$$\begin{aligned} v_o &= K(V_r - v_o) \\ v_o &= \frac{K}{K+1} V_r \end{aligned} \quad (6)$$

Since the duty ratio generated by the control circuit is expressed directly as a mathematical expression of the feedbacks, this kind of control law is named as Function Control. Fig.5 shows the block diagram of this control strategy.

Since no assumption is involved in the derivation of (6), this strategy of Function Control provides the following:

- the result is true for both steady-state and dynamic conditions
- the analysis is valid for both small-signal and large-signal variation because no small-signal assumption is made during the analysis
- v_o is independent of the supply voltage and load current and depends only on the reference voltage
- the result is applicable to all switching converters because no particular topology is assigned

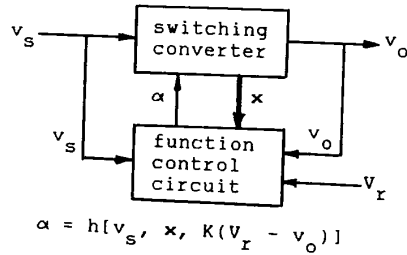

Fig.5 Block diagram for the new strategy of Function Control

III. APPLICATION OF THE FUNCTION CONTROL STRATEGY

From the discussion in the above section, there are three steps to construct the control law of the Function Control strategy for a given topology of power stage:

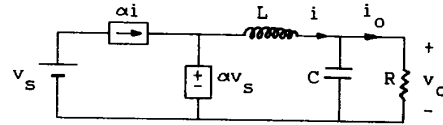

Fig.6 Low frequency equivalent circuit of the Buck converter

- express the averaged time-variant output voltage v_o as a function of the duty ratio α , supply voltage v_s , and some other circuit variables x , i.e., (1),
- rewrite the obtained equation so that the duty ratio α is expressed in terms of v_s , v_o , and x , i.e., (3),
- the control law, i.e., (4), can be deduced by substituting $K(V_r - v_o)$ for v_o in the equation obtained in step (b).

If the control strategy is constructed in this way, the closed-loop output voltage can become independent of the disturbance from either the supply voltage or the load current.

Consider the Buck converter, Fig.1a, as an example to illustrate the application of the Function Control strategy. Its low frequency averaged equivalent circuit is shown in Fig.6 [15]. From the Kirchhoff voltage law, the following equation can be deduced:

$$v_o = \alpha v_s - L \frac{di}{dt} \quad (7)$$

The second step to deduce the control law of Function Control strategy is to obtain an expression for the duty ratio α from (7):

$$\alpha = \frac{v_o + L \frac{di}{dt}}{v_s} \quad (8)$$

The input and output of the control circuit is constructed by substituting $K(V_r - v_o)$ for v_o in (8):

$$\alpha = \frac{K(V_r - v_o) + L \frac{di}{dt}}{v_s} \quad (9)$$

From (8) and (9), the closed loop output voltage is obtained as:

$$v_o = \frac{K}{K+1} V_r \quad (10)$$

Equation (10) is the same as (6).

The Function Control strategies for the Boost, Buck-Boost and Cuk converters, (Fig.1), can also be derived in the same way. The control laws and the key equations for the four basic converters are listed in Table 1.

Table 1. Key equations and control laws for the function controlled Buck, Boost, Buck-Boost and Cuk regulators

	The equation from the power stage	The relation of the control circuit	The output voltage
Buck	$v_o = \alpha v_s - L \frac{di}{dt}$	$\alpha = \frac{K(V_r - v_o) + L \frac{di}{dt}}{v_s}$	$v_o = \frac{K}{K+1} V_r$
Boost	$v_o = -L \frac{di}{dt} + v_s + \alpha v_o$	$\alpha = \frac{K(V_r - v_o) - v_s + L \frac{di}{dt}}{K(V_r - v_o)}$	$v_o = \frac{K}{K+1} V_r$
Buck-boost	$v_o = -L \frac{di}{dt} + \alpha(v_o + v_s)$	$\alpha = \frac{K(V_r - v_o) + L \frac{di}{dt}}{K(V_r - v_o) + v_s}$	$v_o = \frac{K}{K+1} V_r$
Cuk	$v_o = \alpha v_c - L_c \frac{di}{dt}$	$\alpha = \frac{K(V_r - v_o) + L_c \frac{di}{dt}}{v_c}$	$v_o = \frac{K}{K+1} V_r$

IV. RESULTS OF COMPUTER SIMULATION AND EXPERIMENT

Based on the above discussion, the computer simulation by PSPICE is made on a Function Controlled Buck switching regulator. The averaging model of the Buck converter, Fig. 6, is used in the simulation. The control law is the same as (9). The simulation result is shown in Fig. 7.

Fig. 7a is the simulation result when the reference voltage V_r ramps from 12.24V to 15.3V in 400 μ S, the output voltage follows the reference voltage closely. The difference between v_o and V_r is because of the finite value of K . When the supply voltage v_s steps from 20V to 30V, the output voltage remains unchanged at 12V, as shown in Fig. 7b. When load current steps from 1.6A to 2.8A, the output voltage still remains unchanged at 12V, as shown in Fig. 7c.

From Table 1, or (9) for Buck converter, the information needed to implement the function control strategy is the low frequency component of $L di/dt$, which is the low frequency component of the inductor voltage v_L . Because of the switching action, the inductor voltage has a high frequency component in it. Therefore, $L di/dt$ can be retrieved by filtering the switching frequency component of v_L .

It is also noted from Table 1 or (9) that a division operation is needed to get the required duty ratio. An analog divider followed by a modulator can be used here. However, this scheme is expensive and has a narrow band. In the paper, a much simpler divider is used to generate the duty ratio. The duty ratio generator has two inputs, the numerator v_1 (corresponding to numerator of (9)), and denominator v_2 (corresponding to the denominator of (9)). It generates a triangular signal whose peak value is proportional to the denominator v_2 . The numerator v_1 sets the level at which a comparator is triggered. As a result, the output of the duty ratio generator is a pulse signal whose duty ratio α is proportional to the ratio of v_1 and v_2 .

The implementation of the Function Control strategy is illustrated in Fig. 8 and is simple. The inductor voltage is low-pass filtered. The amplifiers are employed to synthesize the numerator and the denominator according to Table 1 or (9) for Buck converter. The output v_1 and v_2 are fed to the duty-ratio generator.

It is worthwhile to point out here that by the Function

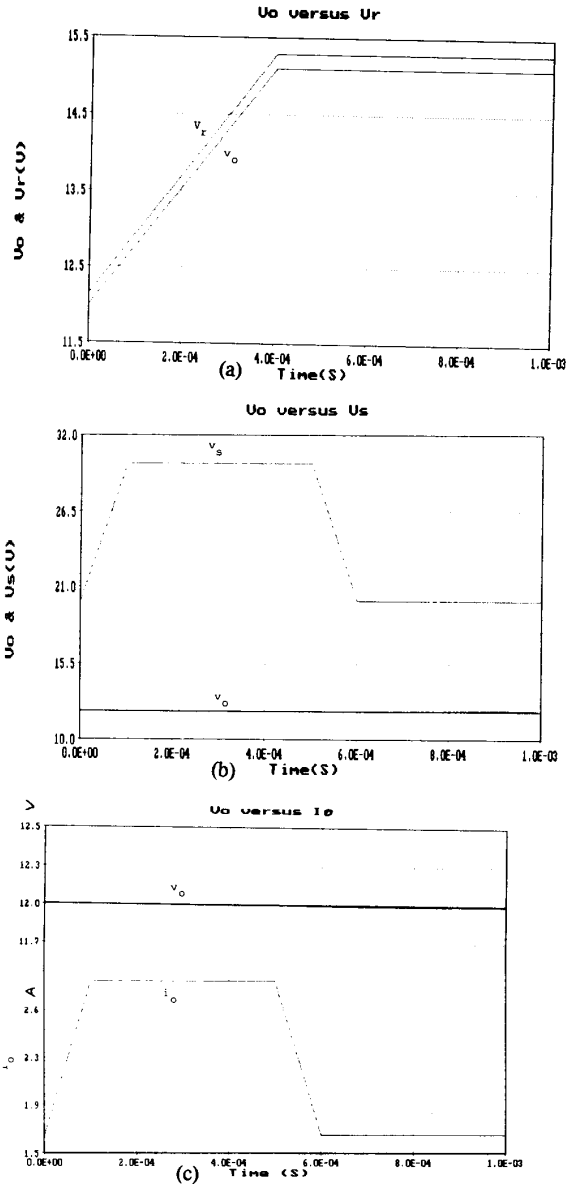

Fig. 7 Simulation results of Function Controlled Buck regulator (a) v_o versus V_r , (b) v_o versus v_s and (c) v_o versus i_o

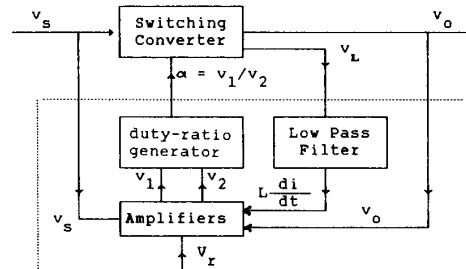

Fig. 8 Block diagram to realize the function control law

Control strategy proposed in the paper, the control circuit is very flexible because when various power stages are used, the only change in the control circuit is the connection of the amplifier, according to Table 1.

A Buck switching regulator prototype controlled by the function control strategy, as shown in Fig.9, is breadboarded in order to verify the analysis. The parameters are: $L=240\mu\text{H}$, $C=600\mu\text{F}$, $v_s=20\text{-}30\text{V}$, $v_o=12\text{V}$, $i_o=1.6\text{-}2.8\text{A}$. Fig.10 and Fig.11 are the experimental results.

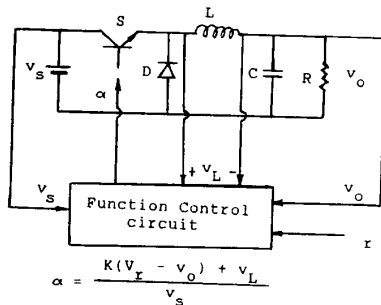

Fig.9 Function control of Buck regulator

Fig.10a shows the waveform of the output voltage when the supply voltage steps between 20V and 30V. The output voltage v_o remains unchanged at 12V. The waveform of v_o is amplified in Fig.10b. Only the amplitude of ripple is changed when the input voltage is changed. The average value of output voltage remains unchanged at 12V. The effect of the feedforward is also tested. If the input voltage v_s is not fed forward, the change of the output voltage is visible when the supply voltage steps from 20V to 30V, as shown in Fig.10c. This demonstrates the usefulness of feeding forward v_s .

Fig.11 gives the effect of load current change to the output voltage. When the load current changes from 1.6A to 2.8A, the response of the output voltage is shown in Fig.11a and 11b. No change of v_o is observed in Fig.11a. The detail of the variation of the output voltage is shown in Fig.11b, where the ripple in v_o is enlarged. There is a small change in the average value (4mV) of the output voltage v_o (12V), which can only be seen in Fig.11b. The percentage regulation is $0.004/12 = 0.033\%$, which is very small. This small voltage change is caused by the voltage drop of the switching devices. Fig.11b shows that the dynamic error (change during transition) is very small. In order to show the influence of the inductance voltage feedback, measurement is also made when the inductor voltage v_L is not feedback. In this case, the response of the output voltage is shown in Fig.11c, when the load current steps from 1.6A to 2.8A. The dynamic error is significant.

V. CONCLUSIONS

The control strategy of the DC-to-DC switching converter is studied in order to obtain switching regulators with zero-voltage regulation. The proposed Function Control strategy for the DC-to-DC switching converters makes the switching regulator robust. The input and output relation of the control circuit can be derived directly from the equation of the power stage. The basic principle is applicable to the four basic switching topologies. The analysis, experiments and computer simulations show

that the switching regulators by the Function Control strategy have the following advantages:

- The regulator can suppress the disturbance from the supply voltage and the load current;
- The analysis is valid for both small signal and large signal variation;
- The implementation of the control circuit is simple and flexible.

Close agreement is obtained between analysis, simulations and experimental results.

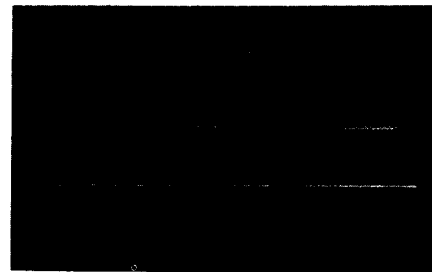

(a)
Upper trace: v_s 5V/div.
Lower trace: v_o 5V/div.

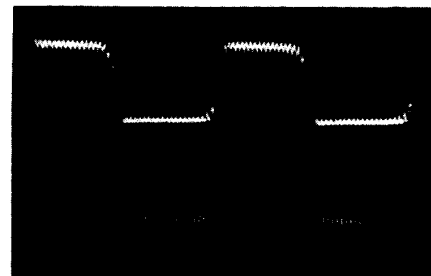

(b)
Upper trace: v_s 5V/div.
Lower trace: v_o 20mV/div.

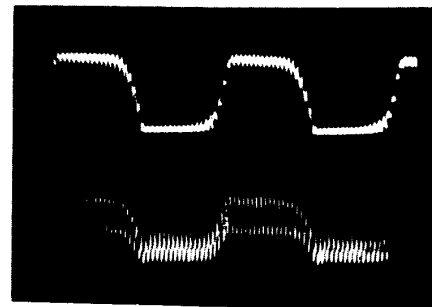

(c)
Upper trace: v_s 5V/div.
Lower trace: v_o 20mV/div.

Fig.10 Effect of supply voltage disturbance
Time: $200\mu\text{s}/\text{div}$.

REFERENCES

- [1] N. Mohan, T.M. Undeland and W.P. Robbins, "Power Electronics: Converters, Applications and Design", John Wiley & Sons, Inc., New York, 1989
- [2] M.H. Rashid, "Power electronics: Circuits, Devices and Applications", Prentice Hall, New Jersey, 1988
- [3] P.C. Sen, "Thyristor DC drives", John Wiley & Sons, Inc., New York, 1981
- [4] P.C. Sen, "Principle of electric machines and power electronics", John Wiley & Sons, Inc., New York, 1898
- [5] C.W. Deisch, "Simple switching control method ychanges power converter into a current source", IEEE PESC record, 1978, pp.300-306
- [6] A. Capel, G. Ferrante, D. Sullivan and A. Weinberg, "Application of injected current model for the dynamic analysis of switching regulators with new concept of LC³ modulator", IEEE PESC Record, 1978, pp.135-147
- [7] R. Redl and N.O. Sokal, "Current-mode control, five different types with the three basic classes of power converters: small-signal AC and large-signal DC chacterization, stability requirements and implementation of practical circuits", IEEE PESC Record, 1985, pp.771-785
- [8] R.D. Middlebrook, "Topics in multiloop regulators and current mode programming", IEEE PESC Record, 1985, pp.716-732
- [9] R. Redl and I. Novak, "Instabilities in current-mode controlled switching voltage regulators", IEEE PESC Record, 1981, pp.17-28
- [10] F. Bilalovic, O. Music and A. Sabanovic, "Buck converter regulator operating in the Sliding Mode", PCI April 1983, pp.331-340
- [11] R. Venkataramanan, A. Sabanovic and S. Cuk, "Sliding mode control of DC-to-DC converters", IEEE IECON Record, 1985, pp.251-258
- [12] S.P. Huang, H.Q. Xu and Y.F. Liu, "Sliding mode controlled Cuk switching regulator with fast response and first order dynamic characteristics", IEEE PESC record, 1989, pp.124-129
- [13] C.K. Tse and K.M. Adams, "An adaptive control for DC-to-DC converters", IEEE PESC Record, 1990, pp.213-218
- [14] Y.F. Liu, X.Z. Zhang and S.P.Huang, "Function control and its application in DC-DC switching regulators", IEEE PESC Record, 1988, pp.377-382
- [15] X.Z. Zhang and S.P. Huang, "Equivalent controlled source model for the PWM switching converters", Electrical Journal, No.3, 1986(in Chinese)

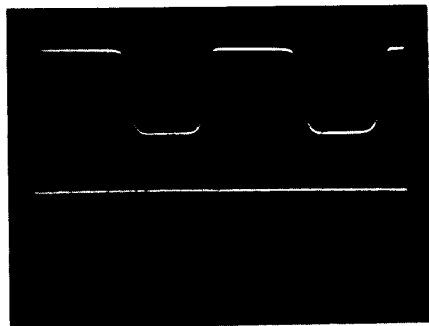

(a)
Upper trace: i_o 0.5A/div.
Lower trace: v_o 5V/div.

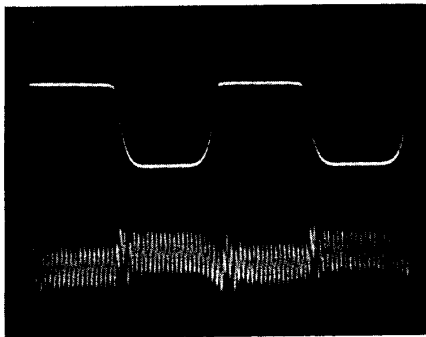

(b)
Upper trace: i_o 0.5A/div.
Lower trace: v_o 20mV/div.

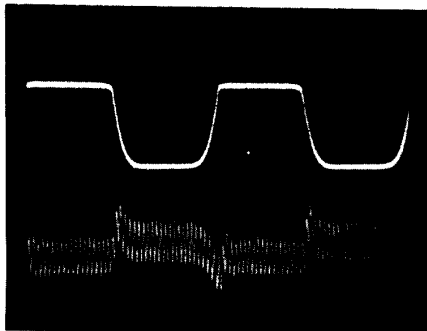

(c)
Upper trace: i_o 0.5A/div.
Lower trace: v_o 20mV/div.

Fig.11 Effect of load current disturbance
Time: 200 μ S/div.